

GLASS-GUARD™ 2800 series

HIGH PERFORMANCE TWO COMPONENT HIGH GLOSS POLYURETHANE TOP COAT

(all color and clear)



PRODUCT FEATURES

- Low V.O.C. (2,8lb / gal)
- Outstanding gloss, color retention and resistance to U.V.
- Remarkable resistance to chemical compounds, impact and abrasion
- In field color matching service available
- Increased corrosion control over Glass Shield moisture cured urethanes and epoxy primers
- Resistance to weathering



Suggested Uses

- Trucks and fleets
- Trains and railcars
- Bridges
- Nautical
- Storage tanks
- Pipelines
- Military equipment
- Water treatment plants
- Refineries
- Pulp & Paper mills
- Any substrate (wood, aluminum, fiberglass, galvanized metal, steel, concrete) exposed to moderate or severe corrosive or abrasive environments.

Technical Data

Coating type	Aliphatic polyurethane resins
Colour	Wide range of colors (Clear gloss also available)
Packaging	3.78 L (1 US Gal.)
Mixing Ratio	2 : 1 per volume with: -275-50C -275-59C -275-80C
Gloss (ASTM D523)	94%
Flashpoint (ASTM D93)	-4° C (25° F)
Induction time	None
Thinner	UC 500S - Regular GS 262-17S - Slow
Pot life	GS 275-50C : 6 hours GS 275-59C : 8 hours GS 275-80C : 3 hours
Shelf life	Part A: 5 years Part B: 2 years

Packaging, Handling & Storage

Shipping weight (approximate)	1 gallon: 8-10 lbs (3.6-4.5kg)	5 gallons: 40-50 lbs (18.2-22.7 kg)
Flashpoint (setaflash)	Part A : 25° F (-4° C) Part B : 56° F (13° C)	
Storage (general)	Store indoors	
Storage temperature & humidity	40-100° F (4-43° C) 0-100% relative humidity	

Density / Organic and clear: (ASTM D 1475) Inorganic:	1.2 avg.
Weight / Organic and clear: Inorganic:	9-12 lb / US gal.
Volatile organic compound (VOC)	2.8 lb / US gal. (336 g)
Temperature resistance	100° C (212° F) in continuous service
Solids (ASTM D1644) / Inorganic Organic	
By weight	55+/- 2% - 48+/- 2%
By volume	42+/- 2% - 55+/- 2%
Theoretical spreading rate	15.5-17 sq.m / l at 25 microns dry
Recommended film thickness	50 - 75 microns dry (2.0 - 3.0 dry mils)
Application methods	Air spray, airless, electrostatic, brush or roller
Dielectrical properties	2000 volts @ 3 mils thickness

Typical Sequence (First class finish)

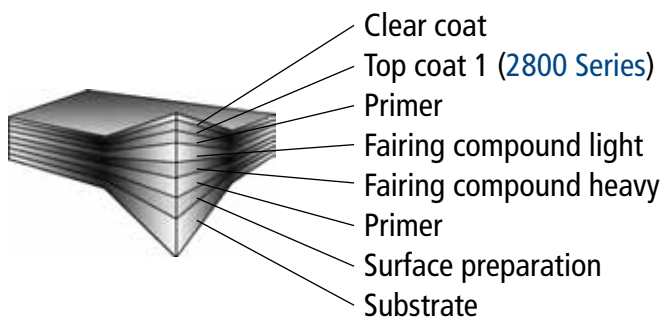

Not recommended for

- Application over bare aluminum
- Application in continuous immersion in water
- CAUTION! Do not apply product when dew can form on the surface in the first 6 hours of cure. Be sure all surfaces are completely free of moisture before applying product.
- DO NOT APPLY PRODUCT IF RELATIVE HUMIDITY IS 90° F OR HIGHER.

In doubt? Contact technical services at 1-800-361-6652 for proper guidance in preparing substrate

Performance Information

Specific Test	ASTM	Result
Hardness: Pencil Gouge end point (air dry: 25° C, 40% RH)	D3363	4H
Hardness: könig pendulum (air dry: 25° C)	D4366	150 seconds
Flexibility (Mandrel)	D522	Pass 1/8 inch
Impact resistance: direct	D2794	76 lbs
Elcometer (pull test)	D4541	> 1000 lbs with Epoxy > 800 lbs with MC-4390
Smoke density	E662-01	Pass
Specular gloss	D523	Excellent > 90%
Direct weathering inland Florida USA 5 deg. South exposure time : 2 years	D4141 Procedure A	Gloss : E=△ 2 Deg. Original: 96% - Final (washed): 94% Color Shift: Ecmc=△ 2.1

Salt Spray

Specific Test	ASTM	Result
System MC-4390 + polyurethane 2800*	B117	5000 hours
System EP 1500 + polyurethane 2800*	B117	2000 hours

Chemical Resistance (spot tests)

Specific Test	ASTM	Result
Solvent	D1308	Very good
Acids	D1308	Very good
Alkali	D1308	Very good
Oil / grease	D1308	Very good
Detergent	D1308	Excellent
Water	D1308	Excellent

*All results based on Glass-Guard 2800002 white

Surface Preparation

In order to obtain adequate adhesion, substrate must be clean, dry and free from any contaminants like: dust, grease, wax, oil, rust, silicone residue and unadhered paint in order to obtain adequate adhesion. Apply Glass Guard 2300 series over appropriate undercoat.





In doubt, contact technical services at 1-800-361-6652 for proper guidance in preparing substrate.

Mixing and Thinning

GLASS-GUARD™ 2800 is a two component product. Catalyst, Part B (GS 275-50C, GS 275-59C, GS 275-80C) must be mixed with part A. It is recommended to always stir Part A before mixing in order to obtain a smooth, homogeneous product. Please refer to the technical data chart in order to mix the proper ratios of polyurethane Part A and Part B. Pot life is 3 to 8 hours at 20°C. In air spray applications, add thinner in order to obtain adequate spraying viscosity.

Note: Drying time will change depending on the catalyst and accelerator used.

Warning: Excessive solvent (over 4%) addition can adversely affect the performance of the coating.

CATALYST	THINNER	VISCOSITY	POT LIFE
			
2 : 1	10 to 30 %	22 to 60 sec.	3 to 6 hrs

Application Conditions

Industry standards are for the substrate temperatures to be above 10° C of the dew point. Condensation due to substrate temperatures below the dew point can cause flash rusting on prepared steel and interfere with proper adhesion to the substrate.

Special application techniques may be required above or below normal application conditions.

Condition	Material	Surface	Ambient	Humidity
Normal	60 - 85° F (16 - 29° C)	60 - 85° F (16 - 29° C)	60 - 90° F (16 - 32° C)	0 - 65%
Minimum	50° F (10° C)	50° F (10° C)	50° F (10° C)	0%
Maximum	90° F (32° C)	100° F (35.5° C)	100° F (35.5° C)	85%

DISCLAIMER: All information is given in good faith. Since conditions of use are beyond the manufacturer's controls, all information contained herein is without warranty, implied or otherwise. All technical data and specifications are subject to change. Please consult with your Glass Shield representative for more detailed coating recommendations. Revised: 01-10-2009



Application

GLASS-GUARD™ 2800 can be applied by airspray, airless and electrostatic. Avoid damp surfaces or high humidity conditions since condensation or fog could settle on the coating before it has cured. Minimum temperature for application: 10°C or 50°F. Temperatures over 30°C or high humidity conditions may shorten the drying times or the pot life. If faster dry times are required, use Glass Shield fast catalyst Part B GS 275-80C. If slower times are needed, use slow catalyst GS 275-59C.

PRESSURE	DRY THICKNESS	INTERCOAT
		
40 to 65 lbs / 10 lbs at the gun Conventional HET or JTI	2.0 to 3.0 mils 1 to 3 coats	15 to 30 minutes

Airless & Air Spray

Manufacturer	Graco	Manufacturer	Devilbiss	SATA
Pump	30 : 1	Spray gun	HET	K3 RP
Fluid hose	3/8" x 100' max	Fluid tip	1.1 ff	1.1
Tip size	309 / 411 / 513/ or equivalent	Air cap	#410 / 414	
PSI	2400 PSI min.	Fluid line	3/8"	3/8"
		Pressure pot	15 - 25 psi	40 psi
		Atomizing air	50 - 60 psi	36 psi

Curing Schedule

Ventilate the substrate for 2 hours after application. Curing times are based on a 2.0-3.0 mil (50-75 micron) dry film thickness. Higher film thickness, insufficient ventilation or cooler temperatures will require longer cure times and could result in solvent entrapment and premature failure of the film. Maximum recoat time is 72 hours without special surface preparation. Consult technical services for recommendations and test results. If the maximum recoat time has been exceeded, the surface must be sanded or prepared with a brush off blast SSPC-SP-7 prior to the application of additional coats. GLASS-GUARD™ 2800 applied below 40°F (4°C) may temporarily soften for several hours, after temperatures rise to 60°F (16°C). This is a normal condition and will not influence performance.

Catalyst	275-50C	275-59C	275-80C
Between coats	Min 10 min. 72 hours max	Min 10 min. 72 hours max	Min 10 min. 72 hours max
Dry to touch	2-3 hours	3-4 hours	1 hour
Tape free	12-16 hours	24 hours	+10 hours
Hard	8 hours	10 hours	7 hours
Full cure	7-10 days	10 days	7 days



PAINT SOLUTIONS

FOR EVERY INDUSTRIES



GLASS-GUARD™
2800 series